

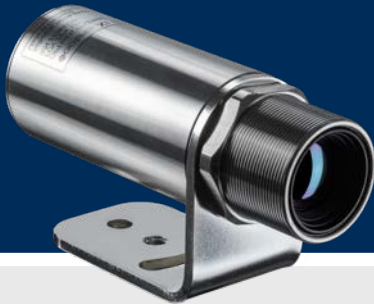

**Compact spot finder
IR camera for measurement
through flames from
475 °C up to 1700 °C**



Xi 410 MT infrared imager measuring through flames inside a furnace

Features:

- Industrial imager with 320 x 240 pixels
- Accurate temperature measurement through flames in the range from 475 °C to 1700 °C to monitor workpieces inside furnaces, to measure inside chemical reactors or to observe brick temperature in combustion chambers
- Small sized rugged camera with motorized focus and optional cooling and protection accessories for use under harsh environments
- Autonomous operation with auto hot spot finder and direct analog or alarm output – ideal for OEM use
- Optional stackable industrial PIF with up to 9 analog or alarm outputs
- Software with extensive analysis features and web server capability included

Technical Specifications

Optical resolution	320 x 240 pixels	
Detector	FPA, uncooled (12 µm pitch)	
Spectral range	3.9 µm	
Temperature range	475 ... 1700 °C	
Optical resolution / Frame rate	Ethernet: 320 x 240 pixels @ 30 Hz USB: 320 x 240 pixels @ 5 Hz	autonomous operation: 320 x 240 pixels @ 1.7 Hz
Optics (FOV)	11° x 8° (f = 20 mm) 17° x 13° (f = 13 mm) 29° x 21° (f = 8 mm) 41° x 30° (f = 6 mm)	
Focus	Manual motor focus	
Optical resolution (D:S)	550:1 (11° optics)	
Thermal sensitivity (NETD)	1 K @ 600 °C	
Accuracy	±2 %	
PC interface	Fast Ethernet / USB 2.0 / RS485	
Direct Output / Input	1x analog output (0/4-20 mA) / 1x input (analog or digital); electrically isolated	
Process interface (PIF), industrial	3x analog outputs (0/4–20 mA or 0–10 V) and 3x alarm outputs (relais) / 3x inputs (analog or digital) / fail-safe (LED and relay) stackable up to 3 PIFs; electrically isolated	
Cable length	Ethernet: 1 m (standard), 5 m, 10 m, 20 m (up to 100 m) USB: 1 m, 3 m, 5 m	
Ambient temperature	0 °C ... 50 °C	
Enclosure (size / rating)	Ø 36 mm x 100 mm (M30x1 thread) / IP 67 (NEMA 4)	
Weight (without mounting bracket)	216 - 220 g, depending on lens	
Shock ¹⁾ / Vibration ¹⁾	IEC 60068-2-27 (25G and 50G) / IEC 60068-2-6 (sinus shaped), IEC 60068-2-64 (broadband noise)	
Power supply	5 - 30 V DC / PoE / USB	
Scope of supply	<ul style="list-style-type: none"> • Process imager Xi 410 MT • Ethernet/ PoE cable (1 m)/ USB cable (1 m) • IN/ OUT cable incl. terminal block (1 m) • Mounting bracket with tripod thread, mounting nut • Software package optris PIX Connect 	

¹⁾ For more details see operator's manual

optris Xi 410 MT

Dimensions in mm

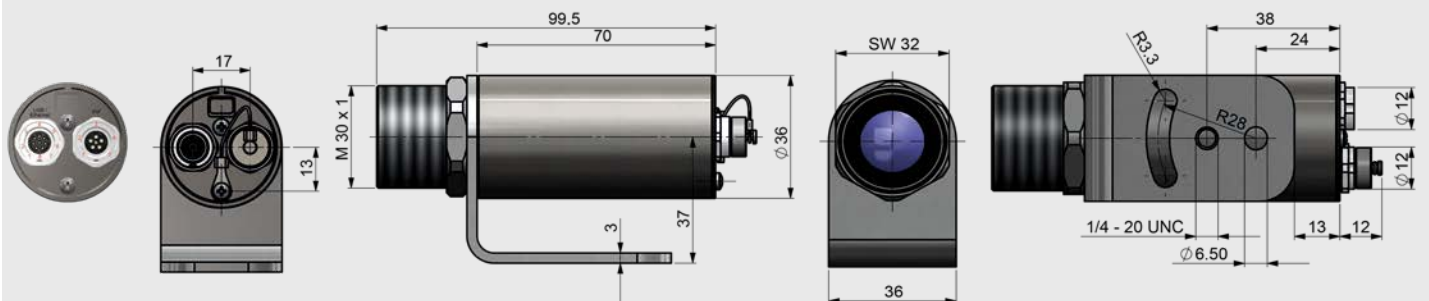

Operation with PIX Connect software and 3 stackable PIFs

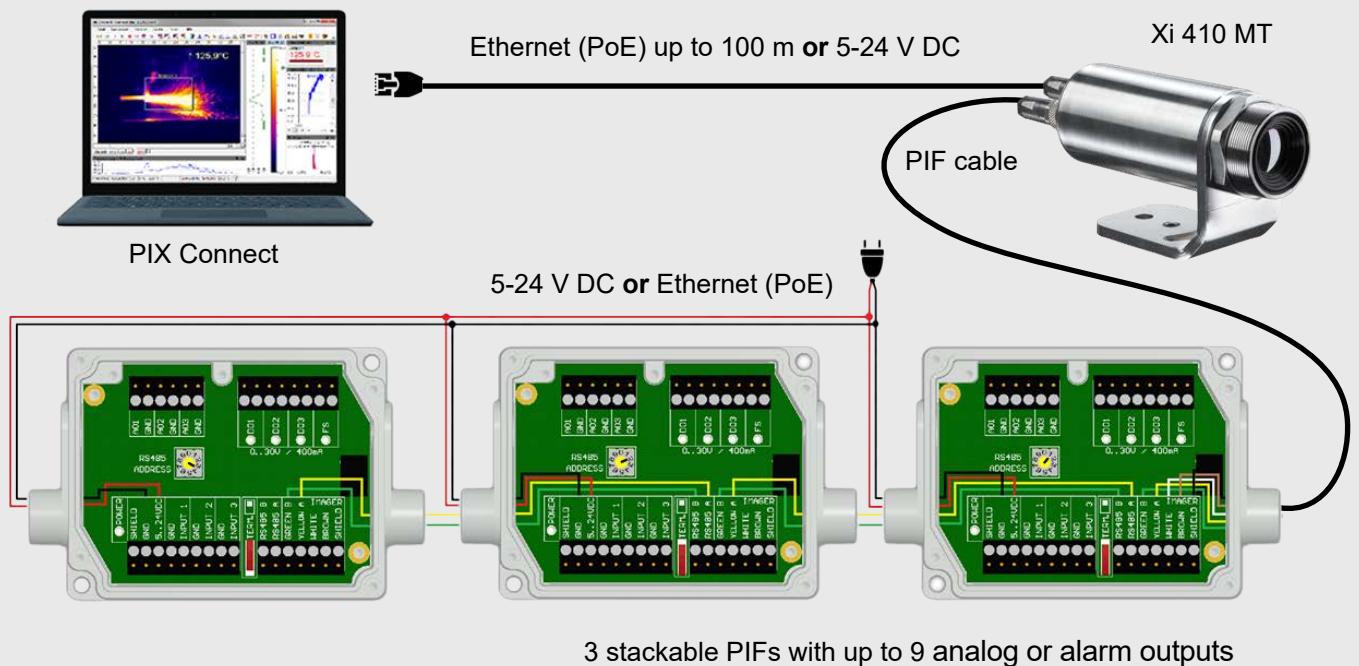

Autonomous operation (without PC) with up to 3 analog outputs/ alarm outputs

